

CD225M Dri-Prime® Pumps

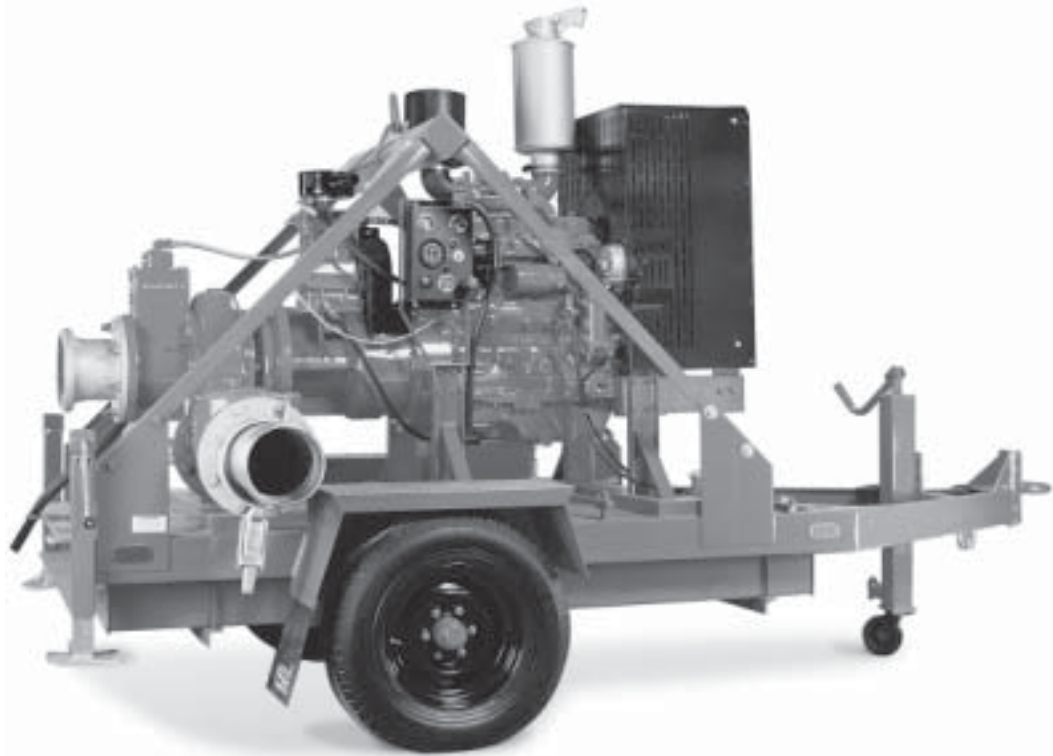

The 8" (200mm) CD225M Dri-Prime is an extremely rugged pump, capable of flow rates to 3200 gpm (726.4 M³/hr.), total dynamic heads to 180 feet (54.9M), and solids handling capabilities up to 3-1/8" (75mm) in diameter. The CD225M also features the unique Godwin high pressure oil bath mechanical seal that allows for indefinite dry running, perfect for intermittent flow applications. All of these features come standard on a highly maneuverable highway trailer or compact skid for convenient use.

Features

- Close mounted arrangement carrying pump and vacuum priming compressor mounted to a diesel engine or electric motor.
- Pumpend available in cast iron, stainless steel and other hardened materials.
- Extensive application flexibility — will handle raw sewage, slurries and liquids with solids up to 3-1/8" (75mm) in diameter.
- Continuously operated "Godwin" air ejector priming device requiring no form of periodic adjustment or control.
- Dry running, high pressure oil bath, mechanical seal with high abrasion resistant silicon carbide interfaces.
- Solids handling swing check Non Return Valve.
- Compact unit mounted on a skid base or two wheeled highway trailer both incorporating integral overnight running fuel tank.
- Simple maintenance — normally limited to checking engine and seal cavity oil levels.
- Standard John Deere 4045T or Caterpillar 3054TA engine. Also available with other diesel engines or electric drive motor.
- Silenced units can be supplied.
- Balanced unit with centralized lifting bracket for easy handling.

CD225M Performance Curve

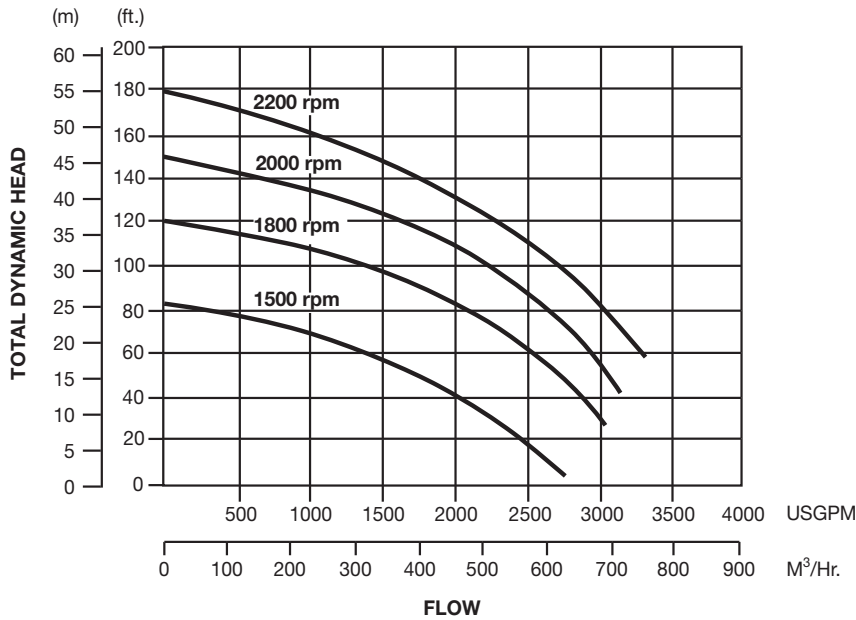

Performance Table

Diesel Set: John Deere 4045T, 99 hp (74 kw) @ 2200 rpm
 Caterpillar 3054TA, 108 hp (81 kw) @ 2200 rpm
Impeller Diameter – 11 3/8 inches (290 mm)

| Total Suction Head — Feet | Total Delivery Head — Feet | | | |
|---------------------------|----------------------------|------|------|------|
| | 40 | 60 | 80 | 100 |
| 15 | 3000 | 2950 | 2640 | 2220 |
| 20 | 2700 | 2600 | 2350 | 2160 |
| 25 | 2510 | 2300 | 2110 | 1610 |

Performance data listed in table and curves based on water tests at sea level and 68° F (20° C). Larger diameter pipes may be required for maximum flows.

Dimensions

CD225M — shown with John Deere 4045T Engine, Skid Base
 Weight: 4966 lbs. (2,252.6 kg.)

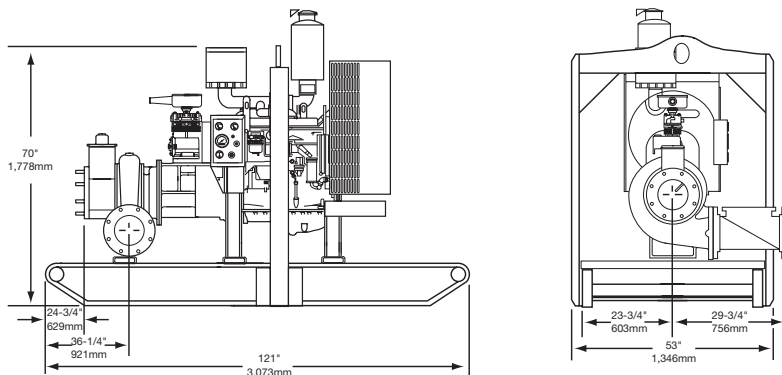

Specifications

- Maximum Operating Speed:** 2200 rpm
- Maximum Operating Temperature:** +212° F (100° C)
- Maximum Working Pressure:** 78.0 psi (5.4 BAR)
- Maximum Suction Pressure:** 88 psi (6.1 BAR)
- Maximum Casing Pressure:** 117 psi (8.1 BAR)
- Fuel Tank Capacity:** 100 gallons (378.5 liters)
- Fuel Consumption** (full load & max. speed):
 John Deere: 4.9 gph (18.55 lph) @ 2200 rpm
 Caterpillar 3054TA: 6.6 gph (25.0 lph) @ 2200 rpm
- Pipe Connections:** 8" (200mm) ASA 150#
- Solids Handling:** 3-1/8" (75mm) diameter

Materials

- Pump Casing, Suction Cover, Separation Tank and Wearplates:** Close grained cast iron
- Impeller:** Cast chromium steel hardened to minimum Brinell 341 HB
- Shaft:** 1-1/2% nickel/chromium steel
- Non Return Valve Body-Ejector Housing:** Close grained cast iron
- Non Return Valve Flapper:** High nitrile rubber
- Mechanical Seal Faces:** Solid silicon carbide



Aquatech has two facets to help you with your site specific needs.

For all your Rental and Sales needs call
Aquatech Pump and Power
 Phone: 905-907-7852
 Fax: 905-907-1701

For full "turn-key" contracting solutions call
Aquatech Dewatering Company
 Phone: 905-907-1700
 Fax: 905-907-1701

Email us: info@aquatd.com
 69 Connie Crescent Concord, ON L4K 1L3
 www.aquatd.ca

Dri-Prime® and the color orange for pumps are registered trademarks of Godwin Pumps of America, Inc. Specifications and illustrations are subject to revision without notice. © Copyright 2002-2003 Godwin Pumps of America, Inc.